

Welded Plate Heat Exchangers

FunkeBlock FPB / FunkeFlex FPF



With partnership into the future

FUNKE is a leader in the development and production of quality heat exchangers with a heat transfer area of up to 2400 m². The range of products comprises shell-and-tube heat exchangers, bolted and brazed plate heat exchangers as well as oil/air cooling units and electrical oil pre-heaters. Thus, as one of the few producers worldwide, FUNKE offers solutions with optimum thermodynamic designs for different industries and virtually all applications.

FUNKE focuses on customer orientation, highest quality standards, flexibility and advisory skills – important benefits a company of just the right size is able to offer.

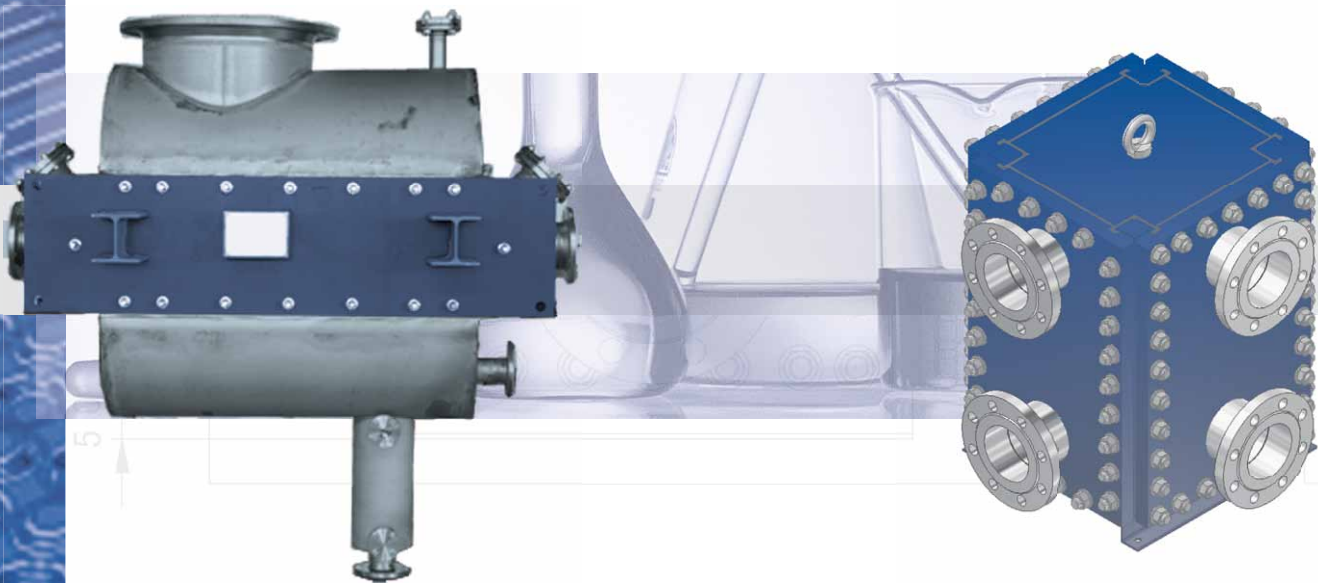

FunkeBlock FPB and FunkeFlex FPF – completely welded flexibility in all sizes!

The FunkeBlock FPB and FunkeFlex FPF welded plate heat exchangers are your perfect solution when it comes to high temperatures and aggressive media. These types of heat exchangers are used, for example, in heat recovery or condensing processes in refineries, in the chemicals and pharmaceuticals industry and in a wide range of other industries. Thanks to their compact design, with very large heat transfer surfaces, these types of heat exchangers have extremely low space requirements and are also easy to service.

The media used in the heat exchange process are supplied and drained through nozzles installed on the covers (FPF) or casing plates (FPB). The media flow through the plate assembly in a cross-flow / cross-counter-flow pattern, with heat from the hotter medium being transferred to the cooler medium. On account of the turbulent thin-layer flow present, this heat transfer is substantially more effective than for other heat transfer models. Baffles can also be employed to ensure that the media pass through the heat transfer process repeatedly.

FunkeFlex FPF

Design and Function

The FunkeFlex FPF is a welded, seal-free plate heat exchanger, whose core consists of a welded plate assembly made of stainless steel. A number of parameters, such as design, dimensions, connections, internals, etc. can be freely selected, or are available as options. This heat exchanger can be used in nearly all sectors of thermal process engineering, thanks to the flexible selection of flow path, or different types of plates (Tubular, Chevron and Dimple). With its maximum heat exchange area of 8 000 m² the FunkeFlex satisfies all the demands for an absolutely versatile heat exchanger.

Technical Data

- max. permissible operating pressure: 40 bar (g)
- min. permissible operating pressure: -1 bar (g)
- max. permissible operating temperature: 600°C
- min. permissible operating temperature: -40°C

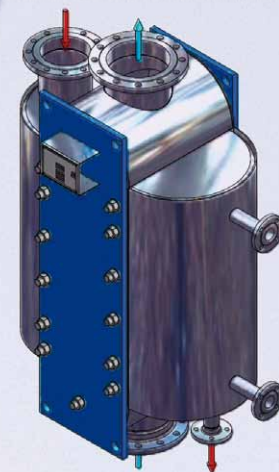

Plate type	Gap	Plate width		Plate length		Dimensions			N1 + N2 from DN	Connections	
		from	to	from	to	A1	B1	L1		N3 + N4 to DN	
		mm	mm	mm	mm	mm	mm	mm			
Tubular	6/9	330	530	216	6000	free selectable			25	2000	
Dimple	5/10	330	730	216	6000	free selectable			25	2000	
Chevron	3	330	730	216	6000	free selectable			25	2000	

FunkeBlock FPB

Design and Function

The FunkeBlock is a welded plate-type heat exchanger with removable, sealed covers whose core consists of a welded plate assembly. Like all items that come into contact with the media, this core is made of stainless steel and, in contrast to the standard casing, can be tailored to meet specific demands. The standardized design of the compact FunkeBlock stands out thanks to its flat cover, its extremely efficient heat transfer and its high, specific heat surface density m²/m³ of free space. A main feature of the FPB is also its ability to be easily cleaned.

Technical Data

- max. permissible operating pressure: 32 bar (g)
- min. permissible operating pressure: -1 bar (g)
- max. permissible operating temperature: 300°C
- min. permissible operating temperature: -40°C

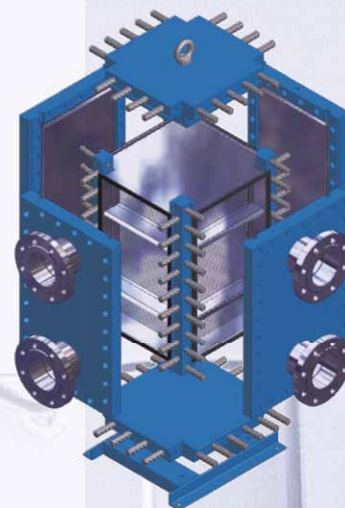

Using the types of plates available for welded plate assemblies (Tubular, Chevron and Dimple), the demands dictated by the flow paths and properties of various media and applications can always be satisfied.

Seals can be selected as appropriate, based on their resistance against media or temperatures.

Overview of different models

FPB30-60-240				FPB50-100-350				FPB75-150-500			
Type	A1	B1	L1	Type	A1	B1	L1	Type	A1	B1	L1
	mm	mm	mm		mm	mm	mm		mm	mm	mm
FPB30-60	486	456	572	FPB50-100	686	672	886	FPB75-150	886	888	1286
FPB30-80	486	456	724	FPB50-150	686	672	1266	FPB75-200	886	888	1666
FPB30-100	486	456	876	FPB50-200	686	672	1646	FPB75-250	886	888	2046
FPB30-130	486	456	1104	FPB50-250	686	672	2026	FPB75-300	886	888	2426
FPB30-160	486	456	1332	FPB50-300	686	672	2406	FPB75-350	886	888	2806
FPB30-200	486	456	1636	FPB50-350	686	672	2786	FPB75-400	886	888	3186
FPB30-240	486	456	1940					FPB75-450	886	888	3566
								FPB75-500	886	888	3946

Quality means safety. Each unit built by FUNKE is design and pressure tested. Additional approvals are also available in accordance with quality authorities such as:



- American Bureau of Shipping (ABS)
- Bureau Veritas (BV)
- Det Norske Veritas (DNV)
- Germanischer Lloyd (GL)
- Lloyds Register of Shipping (LRS)
- Schweizerischer Verein für technische Inspektionen (SVTI)
- Technischer Überwachungsverein (TÜV)

as well as customers' test and inspection regulations.

FUNKE has been certified according to DIN EN ISO 9001:2008 and is an approved manufacturer according to:

- EU Pressure Equipment Directive 97/23/EC (PED), Module H/H1
- HP0 in connection with DIN EN 729-2
- ASME U-Stamp
- GOST R (incl. RTN & hygiene certificate)
- China Certificate



Funke Wärmeaustauscher Apparatebau GmbH
Zur Dessel 1
31028 Gronau/Leine · Germany

T +49 (0) 51 82 / 582-0
F +49 (0) 51 82 / 582-48

info@funke.de
www.funke.de